

# eSync

*Portable hydraulic multi-point motion control system*  
Synchronous lifting/lowering, or pushing/pulling for heavy objects.



# PORTABLE AND EXPANDABLE MOTION CONTROL SYSTEM

## eSync Hydraulic Synchronous Lifting/Lowering Solution

The Power Team eSync portable synchronous system is a combination of digital actuation and digital control. The PLC-controlled eSync is a high accuracy solution to lift or lower an object within a tight tolerance. Synchronous lifting helps to eliminate unwanted stress on the object while the eSync standard features offer the ultimate in user and object safety.

eSync is an economical direct replacement for multi-point motion control systems or split flow pumps.

The eSync utilizes a 4-point light-weight platform, linkable to 16 eSync units and 64 points.

Easily transport the system to the job site with the eSync compact portable package that breaks down into 3 easy to carry sections (eSync, Pump, Storage). This allows a two-man carry to the lifting zone to position the eSync with the included uCage modular stackable workstation, simply stack and quick-pin to create the synchronous tower.

For the ultimate in portability or remote projects choose the battery powered complete system from hydraulic pump to eSync motion control or select from your choice of voltages that fit your requirement.

whether it is a bridge, a building, or any kind of heavy load, with the Power Team eSync, lifting, lowering, pushing, pulling, or positioning loads can be carried out automatically with a high degree of accuracy.

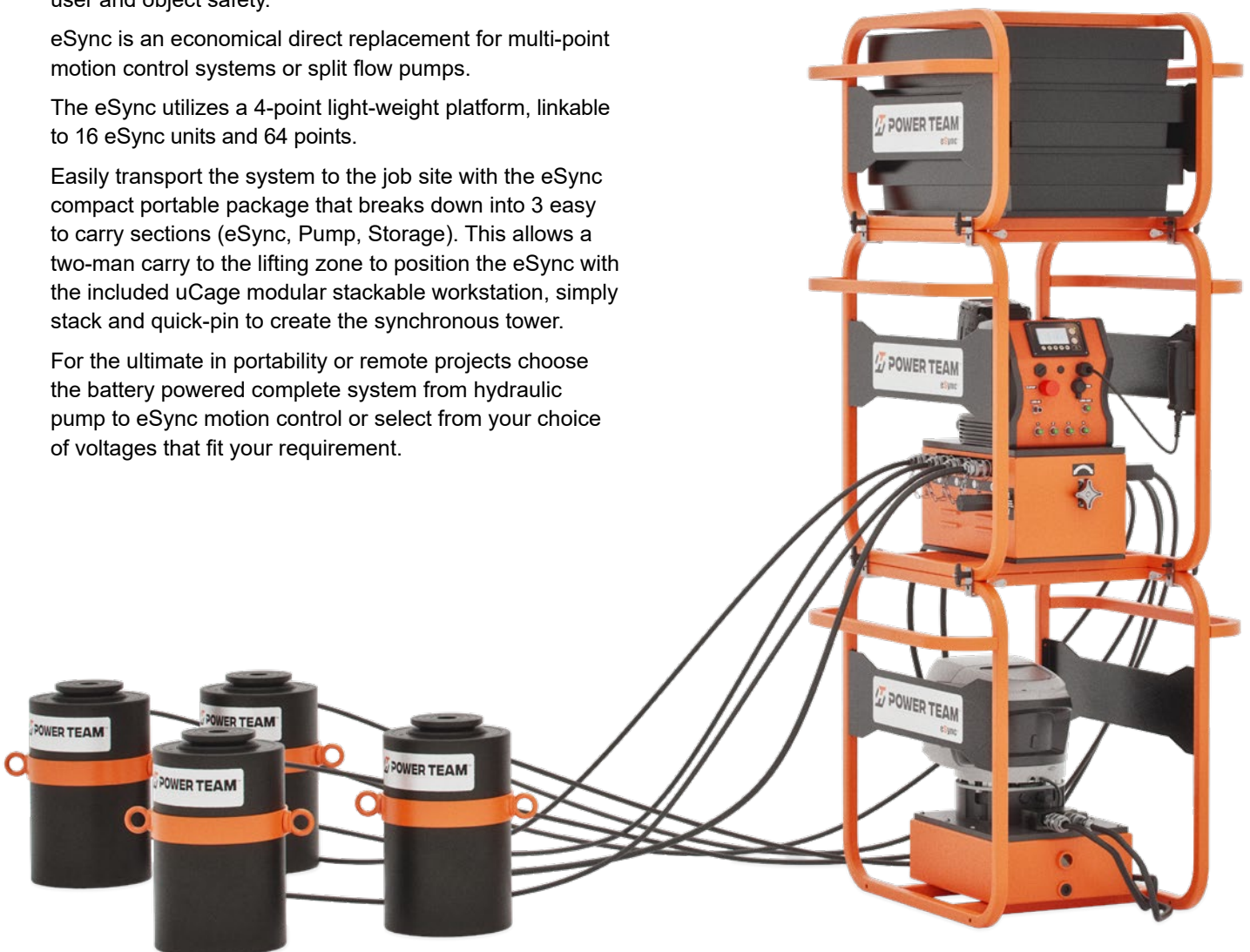

# eSync KEY FEATURES

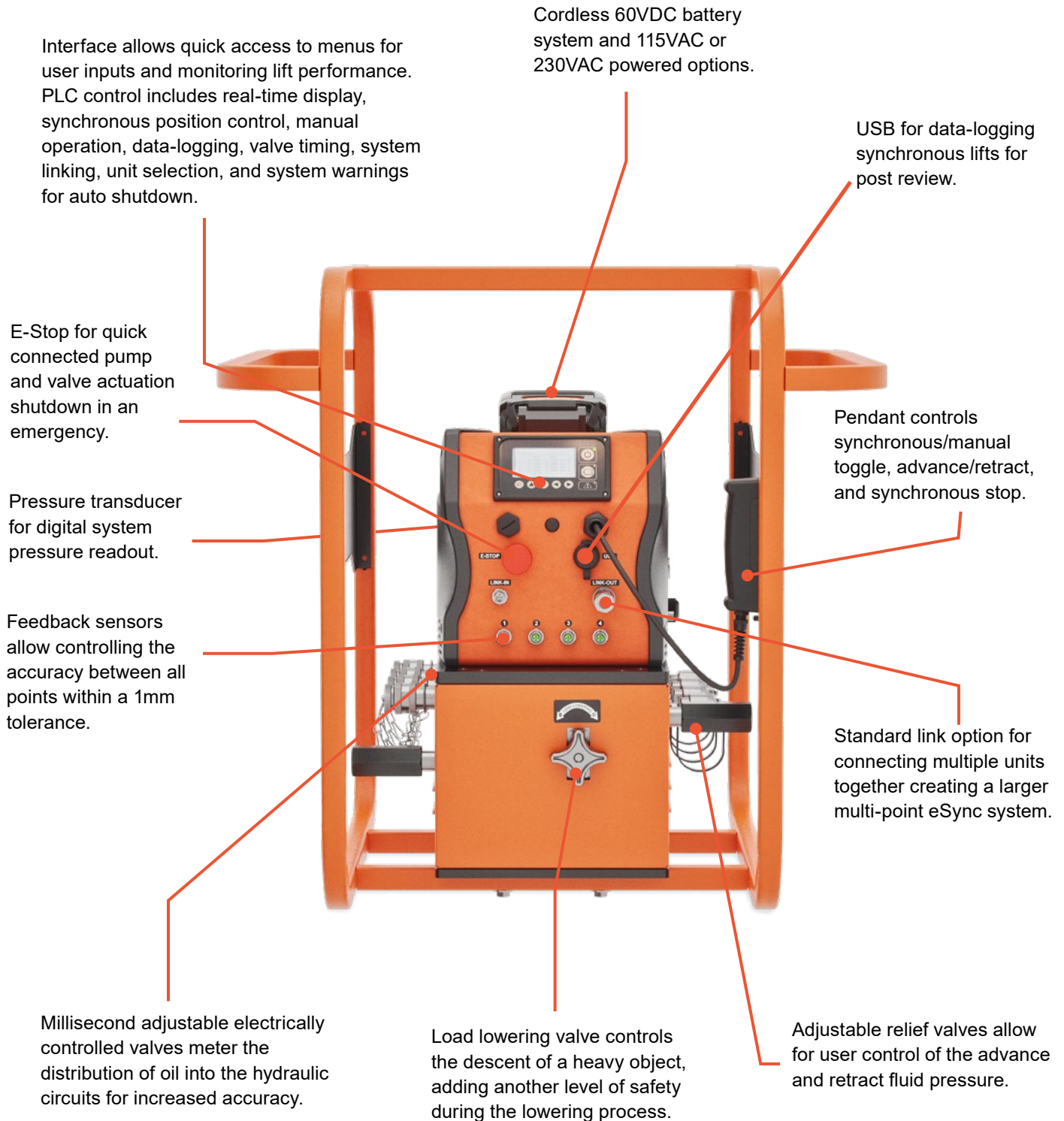

# PB43 (Cordless) AND PE60 (Corded) HYDRAULIC PUMPS

PB43 cordless 60VDC battery system featuring a Li-ion 60VDC, 8.0 Ah battery with 4 level battery life indicator, 1.5 Hour battery charge time from drained to full. Battery chargers available in 115VAC 60HZ and 220AC 50HZ options. PE60 corded pumps available in 115VAC or 230VAC powered options.

Ergonomic 2-person carrying handle on cage for maximum comfort.

Weatherproof ratings:  
Pump rated: IPX4

Plug and play manifold – easy hose connection.

Industry leading, field proven, Power Team Vanguard Pump technology.

Lightweight and portable.  
Great performance-to-weight ratio.

Cordless PB43 3.0 gallon hydraulic oil reservoir with sight gauge. Corded PE60 2.5 gallon hydraulic oil reservoir.

Two-stage, high-pressure (10k PSI) hydraulic pump offers unloading valve that achieves greater pump efficiency with quick tool advancement in the first stage, while shifting to high pressure second stage when demanded.

Easy access hydraulic fluid drain port.

Protective and stackable uCage comes standard with PE60 or PB43 hydraulic pumps.



# uCage & ADDITIONAL FEATURES

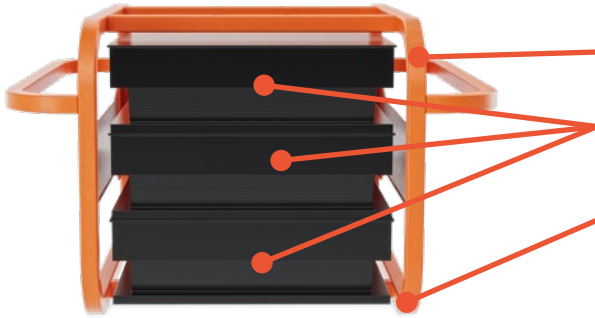

Protective and stackable uCage comes standard for the eSync, storage totes, and hydraulic pump.

Three on-board stackable totes allow protection and storage of position sensors and cables.

Lock-in-place design with secure strap for hassle-free transportation.



Handheld pendant controls the auto and manual functions allowing a remote position for better visual operation with included storage holster.

Pendant controls auto synchronous/manual toggle, advance/retract, and stop operation for safety situations that require a quick override.

Ergonomic IP55 rated remote pendant with 12 ft / 3.6m cord and large button design.

Pendant buttons require low finger depression force to operate for decreased operator fatigue.

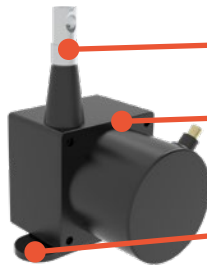

39.4" (1000mm) linear position sensors give feedback to the PLC for load location.

Position sensors allow synchronous movement accuracy to .040" (1mm).

Linear position sensors include magnet kit to mount to load or cylinder.



Li-ion 60VDC, 8.0 Ah battery with 4 level battery life indicator.

1.5 Hour battery charge time from drained to full.

Charger available in 115VAC 60HZ or 230VAC 50HZ.

Global battery compatible with both charger styles.

# eSync TECHNICAL INFORMATION

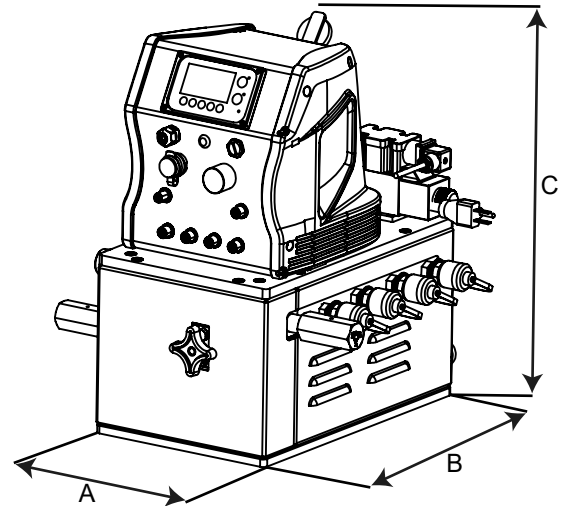
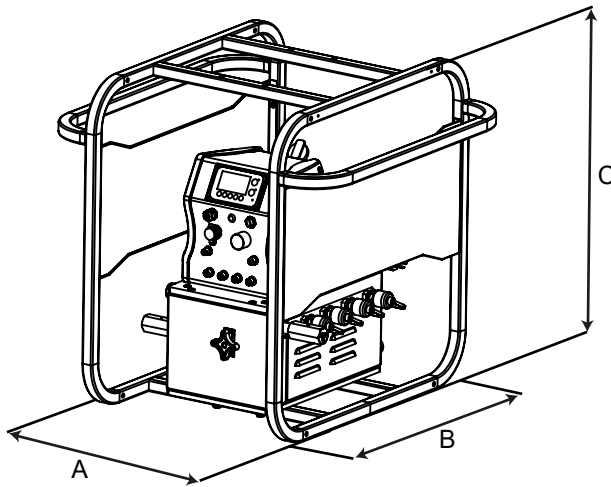

Order No.	With uCage in/(mm)			Without uCage in/(mm)			Pump Included	Voltage	Battery/Charger Included	Sensors/Transducers Included	**Weight lb (kg)
	A	B	C	A	B	C					
ES14PRTXA							N/A	115VAC 60HZ	N/A		130 (59)
ES24PRTXA							N/A	230VAC 50/60HZ	N/A		130 (59)
ES64PRTYXA							N/A	60VDC 8Ah	115VAC 50/60HZ Charger		132 (59.8)
ES64PRTZXA							N/A	60VDC 8Ah	*230VAC 50/60HZ Charger	(1) System pressure transducer & (4) linear position sensors	132 (59.8)
ES14PRTXD	19.0 (482.6)	27.0 (685.8)	27.0 (685.8)	15.0 (381)	16.0 (406.4)	19.22 (488.18)	PE601MX2 hydraulic pump	115VAC 60HZ	N/A		231 (104.8)
ES24PRTXD							PE602MX2 hydraulic pump	230VAC 50/60HZ	N/A		231 (104.8)
ES64PRTYXB							PB43MX2-1 hydraulic pump	60VDC 8Ah	115VAC 50/60HZ Charger		239 (108.4)
ES64PRTZXB							PB43MX2-2 hydraulic pump	60VDC 8Ah	*230VAC 50/60HZ Charger		239 (108.4)

\*EU STYLE PLUG \*\*ESYNC WEIGHT: WITH UCAGE

## Features

eSync includes 4 standard double acting hydraulic points, linkable to 16 eSync units and 64 points.

Systems can be completely cordless for reliable remote operation or corded when power is available.

eSync units are available without a pump or included with Power Team PB43 (cordless) or PE60 (corded) hydraulic 10K PSI pumps.

Systems that include a pump come with everything you need to get started. Just add cylinders and hydraulic hoses for a complete system ready to lift.

eSync battery supplies hours of continuous run time based on demand with 1 fully charged 8ah battery.

## Safety features

full stop due to power failure, sensor failure, tolerance error, linked connection, time out and many more control and pendant warnings.

Protective and stackable uCage elevates the control height for improved operation and the overhead totes offer sun protection that improve display visibility.

Lightweight modular design allows for two-person carry for easy transport, setup, and teardown.

## Accessories

Accessory Part #	Description
3001434	LINKING CABLE 100' ASSEMBLY - ALLOWS CONNECTION OF MULTIPLE eSYNC UNITS

# PUMP TECHNICAL INFORMATION

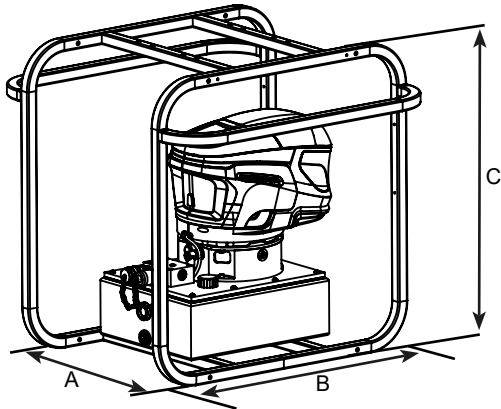

ABOVE: PB43 w/ uCage

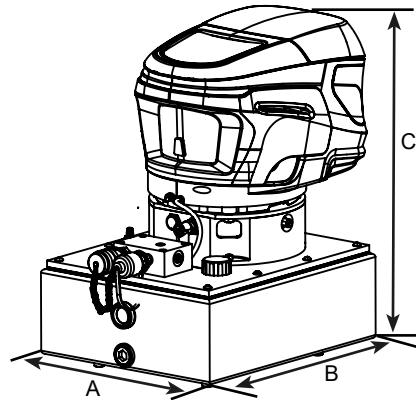

ABOVE: PB43

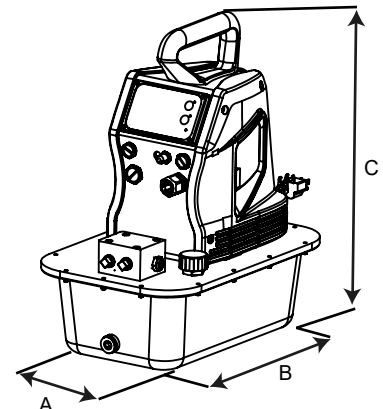

ABOVE: PE60

Order No.	With uCage in/(mm)			Without uCage in/(mm)			Voltage	Battery/Charger Included	RPM	dBA Idle/Max Press.	Oil Delivery - l/min (cu.in/min) @			**Wt lbs (kg)
	A	B	C	A	B	C					7 Bar (100 psi)	350 Bar (5k psi)	700 Bar (10k psi)	
PE601MX2	19.0 (482.6)	27.0 (685.8)	27.0 (685.8)	10.65 (270.51)	16.15 (410.21)	21.31 (541.27)	115VAC 60HZ	N/A	12k	83/91	11.5 (700)	1.2 (70)	1.0 (60)	101 (45.8)
PE602MX2				230VAC 50/60HZ	N/A									
PB43MX2-1				60VDC 8Ah	115VAC 50/60HZ Charger	3.1k	73/75	7.8 (480)	1.2 (70)	0.7 (43)				
PB43MX-2				60VDC 8Ah	*230VAC 50/60HZ Charger									

\*EU STYLE PLUG \*\*PUMP WEIGHT: FILLED WITH OIL INCLUDING UCAGE

## Battery version features

30 Minutes continuous run time with PB43 hydraulic pump based on demand.

The 60-volt battery powered motor in the PB43 offers increased power that delivers industry leading pump flow performance.

**Powerthon**  
**Limited**  
**Lifetime**  
**WARRANTY**

**ISO 9001 Certified**

**Worry Free**  
**Ownership**

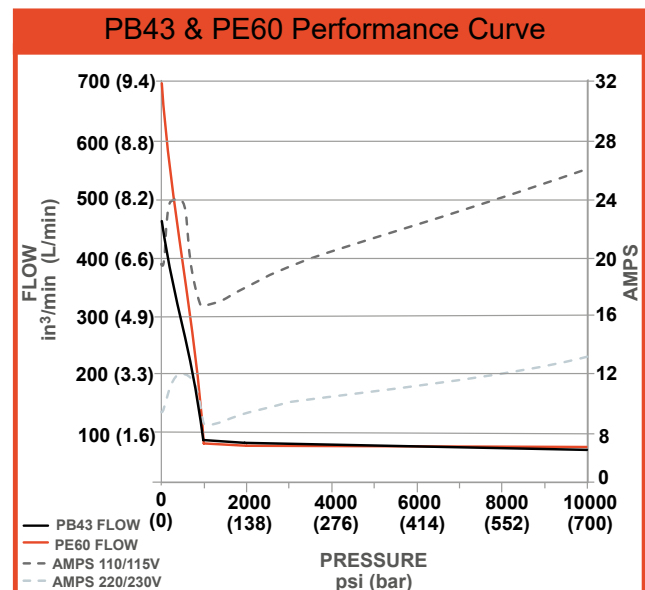

## CUSTOMER SERVICE CENTERS

**Rockford, Illinois USA**  
5885 11th Street  
Rockford, IL 61109 USA  
Tel: +1 800 541 1418  
Fax: +1 800 288 7031  
info.powerteam@spxflow.com

**Gonzales, Louisiana USA**  
3141 S. Darla Avenue  
Gonzales, LA 70737 USA  
Tel: +1 225 774 0888  
info@spxboltingsystems.com

**Houston, Texas USA**  
3106 E Pasadena Freeway,  
Pasadena, TX 77503 USA  
Tel: +1 713 472 2500  
info@spxboltingsystems.com

**Corpus Christi, Texas USA**  
4930 Gemini Street,  
Corpus Christi, TX 78405 USA  
Tel: +1 361-445-3727  
info@spxboltingsystems.com

**Europe**  
Albert Thijsstraat 12  
6471 WX Eyselshoven  
The Netherlands  
Tel: +31 45 567 8877  
cs.emea@spxflow.com

**India**  
Power Team Hydraulic Technologies  
India Private Limited  
Odhav, Ahmedabad - 382 415  
Tel: +91 99099 85454  
Fax: +91 97277 19950  
ft.apac.ht@spxflow.com

**South East Asia**  
Power Team Hydraulic Technologies  
Singapore Pte. Ltd.  
2 Bukit Batok Street 23,  
#02-07 Bukit Batok Connection,  
Singapore 659554  
Tel: +65 6265 3343  
singapore@spxboltingsystems.com

**China**  
Hydraulic Technologies China Ltd.  
No 666, Fengjin Road, Xidu Industrial  
Park Fengxian District,  
Shanghai 201401, China  
Tel: +86 021 2208 5659  
Fax: +86 21 2208 5682  
china@spxboltingsystems.com

**Australia**  
Hydraulic Technologies  
Australia Pty Ltd,  
211 Atlantic Drive, Keysborough,  
Victoria 3173, Australia  
Tel: +613 9589 9215  
Fax: +61 02 9763 7888  
ft.apac.ht@spxflow.com



SCAN THE QR CODE TO WATCH THE VIDEO

Distributed by:



Hydraulic Technologies, reserves the right to incorporate our latest design and material changes without notice or obligation. Design features, materials of construction and dimensional data, as described in this bulletin, are provided for your information only and should not be relied upon unless confirmed in writing. Please contact your local sales representative for product availability in your region. For more information, visit [www.hydraulictechnologies.com](http://www.hydraulictechnologies.com)